

SIDES	BOTTOM
2 3/4" KNOCKOUTS	2 1/2" KNOCKOUTS
7 1/2"-3/4" MOON KNOCKOUTS	2 3/4" KNOCKOUTS
	1 Ground Hump
2 PCS #8-32x1/2 Screws Installed	
Material: Steel-0.0625"-G60 Galvanized	

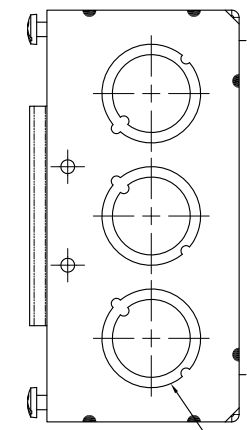
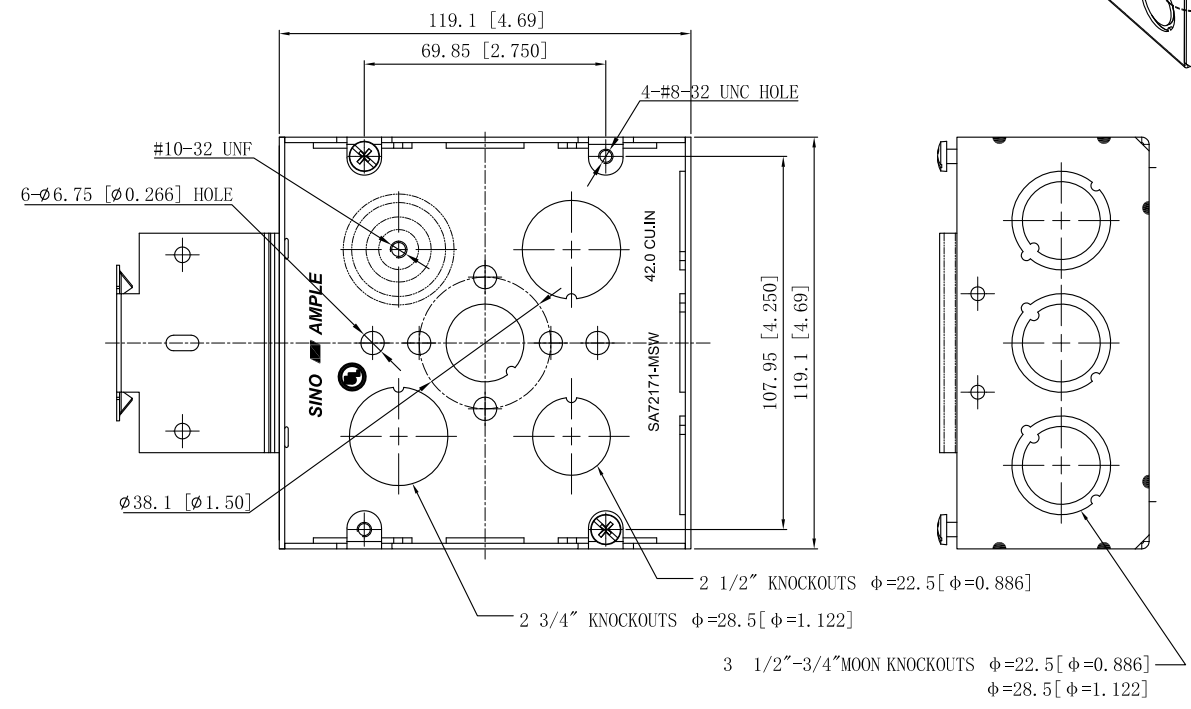
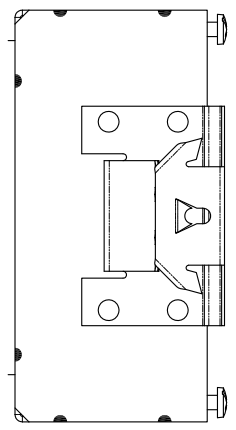
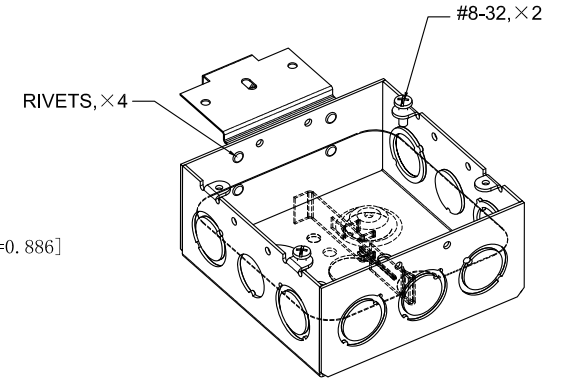
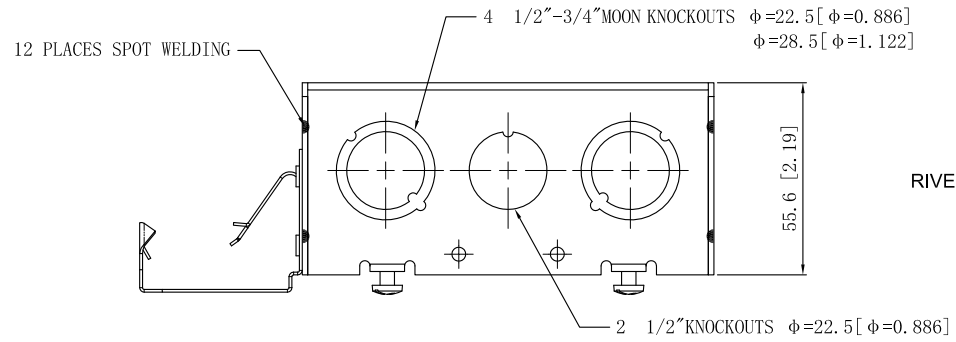

This data sheet is for reference only. SINO AMPLE reserves the right to make changes to the design without prior notice.

DESCRIPTION
TRADE REFERENCE TERMS

STANDARD PACKING	ZHUJI SINO AMPLE METAL PRODUCTS CO., LTD.		
25 PCS	TITLE 4-11/16" SQUARE EXTENSION RINGS 2-1/8" DEEP		
	SIZE A4	DWG NO. SA72171-MSW	REV A
	DATA SHEET		